

TOSHIBA

POWER ELECTRONICS

5000 SERIES 3P1 UPS

**UNINTERRUPTIBLE
POWER SYSTEMS**



ELEVATE YOUR INDUSTRIAL POWER RELIABILITY WITH THE CUTTING-EDGE TECHNOLOGY OF THE 3P1 UPS SOLUTION FROM TOSHIBA

Toshiba's 5000 Series 3P1 UPS is a reliable solution for 3-phase input and 1-phase output back-up power configuration for industrial-grade applications. Built in Houston, the 3P1 is a double conversion UPS and comes with a standard 3 year warranty. The 3P1 Solution is designed to push the boundaries of UPS performance standards in petrochemical, oil and gas refineries, mining, and wastewater applications. Wave Capture is a built-in feature that aids in troubleshooting by capturing and storing voltage and current waveforms at input, output, DC bus, and DC battery link along with a time stamp. All Toshiba 5000 Series models feature industrial rated components designed for a 20-year life span.



5000 Series 3P1 - 30 kVA



5000 Series 3P1 - 15 kVA



5000 Series 3P1 - 50 kVA with MBS + SKRU & Bypass Input ISO Transformer Option

OPTIONS & ACCESSORIES

ENERGY STORAGE SYSTEMS OPTIONS

The Toshiba 5000 Series 3P1 UPS seamlessly integrates with a variety of 125Vdc battery topologies, including VRLA, wet cell, and Lithium-ion batteries, among others. Tailored to meet the unique needs of different industrial applications, backup run-times can range from 2 minutes to 8 hours.

UPS MONITORING

RemotEye® 4 offers real-time control, monitoring, and analysis of UPS operation. RemotEye® 4 also features a first-ever mobile website for monitoring UPS status updates on-the-go. Universal communications protocols compatible with RemotEye® 4 include Modbus® TCP & RTU, BACnet IP & MSTP, HTTP/HTTPS, and SNMP. RemotEye® 4 is compatible with IPv6. The 5000 Series also includes a Human Machine Interface (HMI) with PLC I/O ports to allow customer specific hard wire communication.

INDUSTRIAL END-TO-END SOLUTIONS

Toshiba offers the full array of solutions including input and output isolation transformers, PDUs, bypasses, external chargers, and distribution panels.

5000 Series 3P1 One Line Diagram

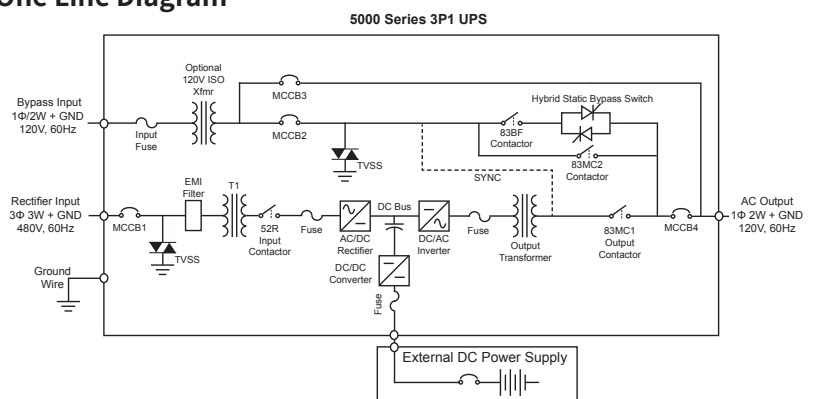

5000 SERIES 3P1 STANDARD FEATURES

- True Double conversion on-line Voltage and Frequency Independent (VFI) UPS
- State of the art robust IGBT topology
- 65kAIC-Rating
- Fuse-less TVSS on all inputs
- 125V DC Battery Link
- Copper-wound Galvanic isolation transformers
- Wave Capture Troubleshooting tool
- Merv 7 Air Filters
- Programmable I/O Ports
- LED Operation Status Indicators
- LED Breaker Status Mimic Panel
- Keyed Doors
- Dead front and EPO switch
- IPC Class 3 Printed Circuit Boards
- Industrial rated components designed for a 20-year life span
- Assembled in the U.S.A at the Toshiba International Corporation manufacturing facility in Houston, Texas

3P1 UPS OPTIONS

- Internal Wrap-around bypass (MBS) with mechanical keyed interlock or SKRU
- External Stand alone or Wall Mount Wrap-around bypass (MBS) Cabinet with mechanical keyed interlock or SKRU
- Toshiba RemotEye® 4 Multi-Protocol UPS Monitoring Solution
- External Battery Chargers with blocking diodes
- Conformal Coated circuit boards
- Spare Part Repair Kits
- Galvanic Isolation Transformers on Alternate bypass input
- Toshiba SCiB Lithium-ion Battery offering
- 240/120 V Output Copper wound Transformers



Toshiba RemotEye® 4 Monitoring Card

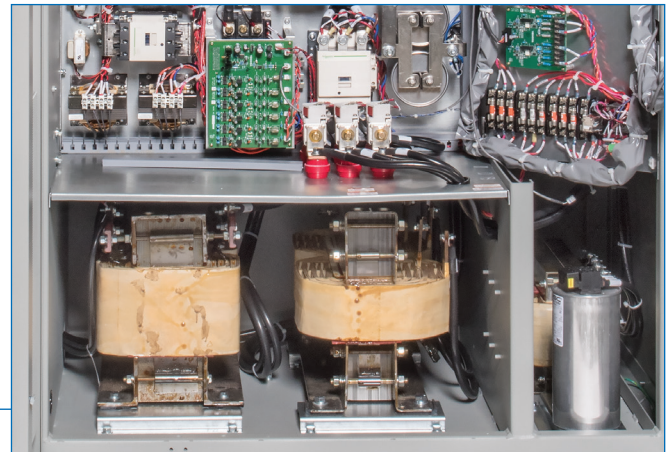

Copper Wound Magnetics & Industrial Components



5000 Series 3P1 - 50 kVA with MBS + SKRU & Bypass Input ISO Transformer Option



5000 Series 3P1 15 kVA

INDUSTRIES SERVED

- Oil and Gas
- Chemical Plants and Refineries
- Distributed Control Systems
- Switchgear and Utilities
- Telecommunications
- Water/Wastewater



TOSHIBA 5000 SERIES 3P1 SPECIFICATIONS

MODEL			
Model Number	50P0K010KWAN, 50P0K015KWAN	50P0K020KWAN, 50P0K025KWAN, 50P0K030KWAN	50P0K040KWAN, 50P0K045KWAN, 50P0K050KWAN
Capacity	10/15 kVA	20/25/30 kVA	40/45/50 kVA
Topology	Three-Phase In, Single-Phase Out, True On-Line, Double-Conversion Technology		
INPUT			
Voltage (Standard)	480 V +10%/-15%, Three-Phase, Three-Wire + Ground		
Voltage (Bypass)	120VAC, Single-Phase, Two-Wire + Ground		
Power Factor	>0.98@100% Load		
Current THD	<5% @100%, <6% @ 25%		
Frequency	60 Hz		
OUTPUT			
Voltage (Standard)	120 V: Single-Phase, Two-Wire + Ground		
Frequency	60 Hz		
Voltage Regulation	+/-3%		
Power Factor	0.9 Lagging		
Overload Capacity	109% Continuous, 110% to 125% for 10 minutes, 150% for 60 seconds		
BATTERY			
DC Link	120V		
DC Ripple Voltage	<0.5% RMS		
ENVIRONMENT			
Temperature Range	Operation: 32° F(0° C) to 104° F(40° C) max. Optimal Operation: 60° F (15° C) to 86° F (30° C)*		
Relative Humidity	Operation: RH 10 % to 95 % (non-condensing) Optimal Operation: RH 40 % to 60 % (non-condensing)*		
Full-Load Efficiency	84%	83%	83%
25% Load Efficiency	72%	70%	76%
Alltitude	3300 ft. (1000 m) Maximum Without Derating		
Air Filtration	Airflow top-to-front with front-located filters		
Audible Noise	65 - 70dBA @ 1m typical		
DIMENSIONS			
Dimensions	30.5"W x 31.3"D x 78.9" H	65"W x 31.3"D x 78.9" H	95.5"W x 31.3"D x 78.9" H
Weight	1380 lbs. (621 kg)	2310 lbs. (1040 kg)	3218 lbs. (1,460 kg)
ADDITIONAL FEATURES			
Color	ANSI 61 Grey		
Monitoring	Touchscreen LCD Operational HMI, Programmable UPS Status N/O Dry Contacts, LED Operation Status Indicators, RS232C Interface, Optional RemotEye® 4		
Options	Galvanic Isolation Bypass Input Transformers, RemotEye® 4 Intelligent Monitoring System, Remote Status Alarm Panel		
Features	TVSS Included on Primary Input and Bypass, Integrated MBS		
Standards	UL 1778; UL 17025, cUL 22.2, No. 107.1, ANSI C62.41 (IEEE 587), NFPA 70, NEMA PE1-1993, OSHA, ISO 9001; ISO14001, IEC298 IP20		
Warranty	3-Year On-Site Warranty; See Toshiba Warranty Policy for Full Details		
Service	24-Hour, 365-Day Technical Support: 1-877-867-8773		

*Operation of the product at temperature or relative humidity outside the optimal range may affect the life span of the product.